



Series 502-504 Residential Sliding Window



DESIGN FEATURES

- Successfully tested to comply with Australian Standard AS 2047.
- Optional meeting stile strengths cover a large variety of design wind load areas.
- It is possible to re-hand the sliding window after installation - change type slider fixed to fixed slider.
- Opening sashes run on large diameter wheels ensuring smooth operation.
- Standard cam and key type cam handles available and located on the jamb for maximum security.
- Optional ventilation type key lock available.
- Besides the obvious standard windows this system can be fabricated as four light sliders, sliders over sliders and fixed lights out of slider frame.
- Fixed sill has built-in drainage to take care of condensation.
- Sashes will accept up to 6.38mm laminated glass with full wrap around glazing.
- Fixed glass is hard up against the outer face, no ledges to catch dust and beaded from the inside, this allows re-glazing without expensive scaffolding.
- Flyscreens tuck into the head and sill, held by nylon clips on the sides with no rivets.
- We have an extensive range of snap couplers for this window, 90°, 135° and 180° that allow the window to be coupled to window or doors without unsightly rivets & screws.

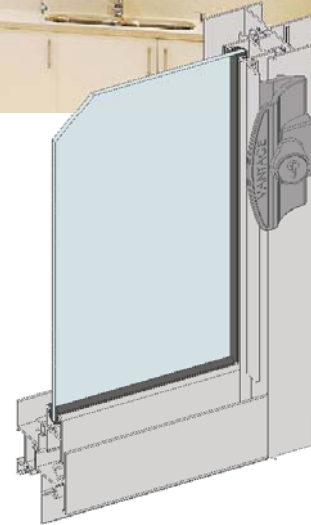

Maximum Panel Height	1500mm
Maximum Panel Width	900mm
Maximum Glass Thickness	≤ 20mm

Subject to individual site conditions. Contact AWS Technical Support for more information.



WERS RATED PRODUCT



ENHANCED ACOUSTIC PERFORMANCE



3D & 2D CAD FILES AVAILABLE



PRODUCT INFORMATION AVAILABLE AT
WWW.VANTAGEALUMINIUM.COM.AU



SPECIFIER ASSISTANCE AVAILABLE

TYPICAL CONFIGURATIONS





Series 502-504 Residential Sliding Window

01.09

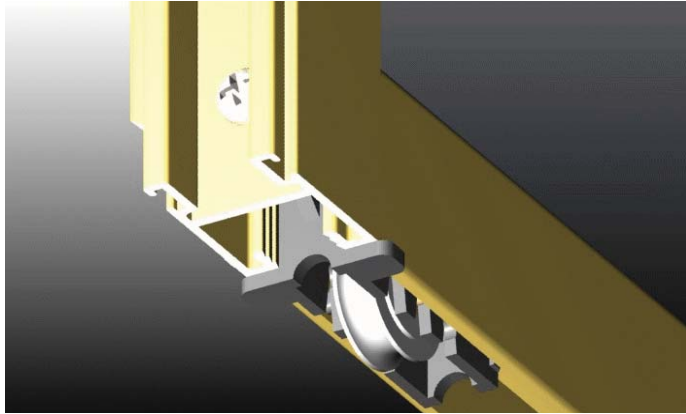

Large diameter wheels used on this window ensure smooth operation for years to come. Compare our wheels with the others. The bigger the diameter the better.

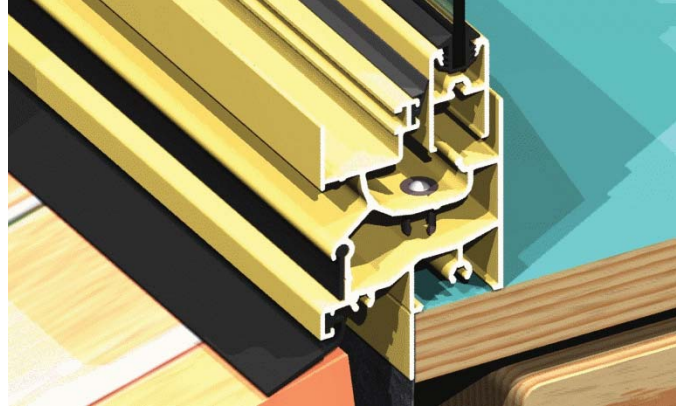

Our standard slider sill performs well but for exposed locations we offer a higher water resisting sump sill as shown above. The sump sill is also fitted with proprietary anti blow back ball valve.



We offer a variety of latches and locks for our sliding windows including the key lock cam shown above.

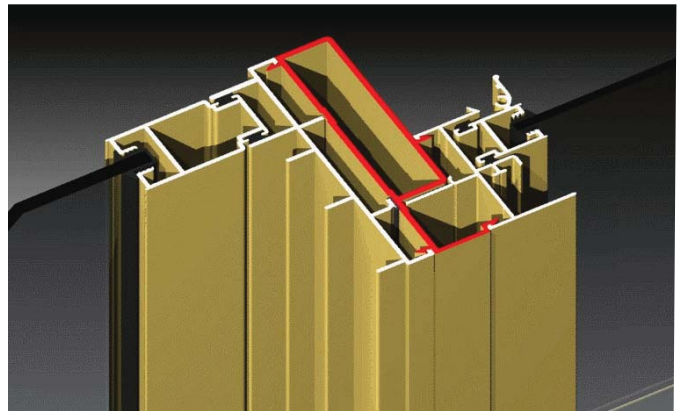

We have numerous couplers for all of our windows and doors. The illustration above shows sliding window clipped to sliding door.



For ultimate security we offer a central ventlock. As you turn the key part of the stile projects into a keeper located in the head. Can be locked in closed or partly open positions.

© Architectural Window Systems Pty Ltd 2002-2009



2D & 3D CAD FILES AVAILABLE
www.vantagealuminium.com.au >
CAD & Revit 3D Files
CAD file: DWG or DXF VAN_502 - 504



MORE INFORMATION
For the latest updates regarding this product visit our web site
www.vantagealuminium.com.au